

# Rakshak – The Death Beater

Yashvardhan Goel, Yashasvi Bhatt, Naman Khanna, Mr. Dinesh Verma

Department of CSE, Global Institute of Technology, Jaipur, India

Received: 15 Jun 2021; Accepted: 27 Jun 2021; Date of Publication: 05 Jul 2021

©2021 The Author(s). Published by Infogain Publication. This is an open access article under the CC BY license (<https://creativecommons.org/licenses/by/4.0/>).

**Abstract** — This project is made with an aim to aid victims of road accidents with effective immediate emergency response. This project is powered by IoT and harness the power of Sensors. The main objective of this project is to inform all the concerned authorities of road accidents without human intervention. Therefore, it has the capability to decrease the death toll that occurred due to road accidents by a significantly good margin. The project starts its execution after it encounters an impact of a certain degree. It then fetches the location of the device and renders it on the map.

**Keywords**— Automation, Death Toll, Location, Sensors, Road Accidents.

## I. INTRODUCTION

### 1.1 Problem Statement

In India, each year, almost 4L - 5L fatalities occur from road accidents, and among these numbers an approximate 1L - 2L people lose their lives due to severe injuries, unavailability of life-saving resources on time. Stats says that in the year 2019 only, 5,89,916 road accidents were reported with a death toll of 1,47,913, and the number of injured fatalities recorded was 4,70,975. This made the fact that 405 people die and 1290 people get injured every day from road accidents, these numbers are even greater than the death toll due to the recent pandemic Covid-19. On some research, we also find that every 7th death occurs due to the unavailability of lifesaving resources on time. So, to decrease these numbers even by a slight margin we are proposing “Rakshak”.

### 1.2 Solution Proposed

Rakshak” is a collection of Hardware and Software utilities, used to perform several tasks thus helping road accident victims with the aid of relief on time from the concerned authorities. We are setting up a device that will be attached to the vehicle, now if some person met with an accident, the device attached will record the intensity of the accident. The in-built GPS device will keep on fetching the location of the device and store it on the server. The software utilities will fetch the location from the server and send it to all the concerned authorities in a radius of

20KMs aiming to get the medical as well as law enforcement response.



Fig.1 Rakshak Mobile App Logo

## II. UTILITIES USED

### 2.1. Raspberry Pi 4B

The Raspberry Pi is a set of tiny single-board computer devices originally made with the purpose of promoting the art of Computer Science in schools and Developing Countries



Fig.2: Raspberry Pi Model 4B

The Raspberry Pi is one of the best-selling Computer Devices with a sale of 40M boards sold till the end of 2020. The reasons that generate these figures are its low cost, modularity, and open design. [1] The Raspberry Pi 4 Model B was released in 2019. It has a 1.5 GHz 64-bit Quad-Core Processor with a certain variety of required utilities like wifi, bluetooth, etc. It came in three different variants which differ from each other by the availability of RAM. Those are 2GB RAM Variant, 4GB RAM Variant and 8GB RAM Variant. It also has a 40-pin pinout. [1] The Raspberry Pi 4 Model B has a certain variety of ports like USB 2.0, USB 3.0 which helps transmit and receive data from other similar or different devices. It also has a USB-C port to provide additional power to the device. [1] The Pi Foundation provides a Linux Distribution, Debian-based 32-bit Operating System as its main OS, although this is not limited, one can use any other Linux Distribution as OS as well but the Foundation Committee recommends “Raspberry Pi OS” (formerly known as Raspbian) as its main OS. The Raspberry Pi promotes Python and Scratch as its main programming languages, although it is also not limited, other programming languages like JAVA or C can also be used. [1]



Fig. 2: Raspberry Pi OS

#### Use in our Project:

The Raspberry Pi is the main system of the Hardware Utility we are designing, all the other hardware components are accessed with the help of Raspberry Pi.

ISSN: 2456-2319

<https://dx.doi.org/10.22161/eec.64.1>

Since all the other Hardware Components generate Analog Signals and Raspberry Pi needs Digital Signal to work upon, therefore an Analog-to-Digital Converter IC Module named as MCP3008 IC Module is used which serves this purpose.[2]

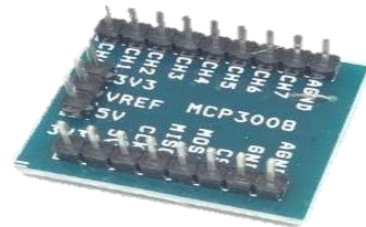

Fig.4: MCP3008 IC Module

#### 2.2 NEO-6M-GPS Module

The NEO-6M GPS module is a module device used to fetch the current location of the device it is attached to. The module sends a request signal to the satellites. This signal is attached with a timestamp at which it was originally transmitted. Then the satellites on the basis of time of request made, respond to it by fetching the coordinates of the device. [3]



Fig.5: NEO-6M GPS Module

The response made by satellite to the request made by the GPS device is in the form of Radio Signals. These Radio Signals carry information about the location and current timestamp of the satellites and inform the receiver about it. [3]

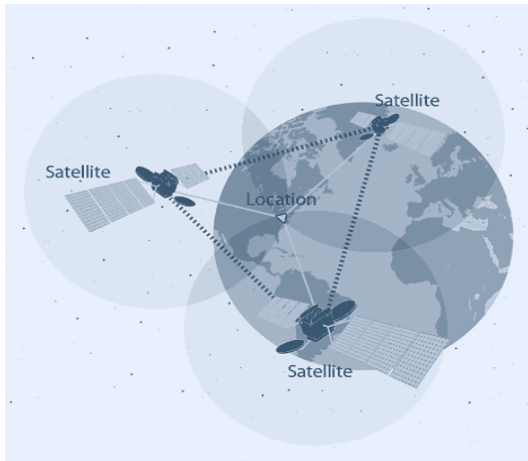

Fig.6: NEO-6M GPS Module Working

The receiver i.e NEO-6M GPS Module in this case uses the Trilateration Process to detect the exact location of Satellites. The receiver calculates the distance between the satellites with the help of the time taken by the receiver to receive response for the request made. [3] It is crystal-oscillated, 12.2 x 16 x 2.4 (mm) sized module device which has the capability to track up to 22 satellites on 50 channels. [4]

**Use in our Project:**

This module fetches the location of the hardware device attached to the vehicle. In any case, an accident happens to the vehicle, the last current location fetched by the GPS Module is stored in the Firebase Server so as to track the accident site.

**2.3. SIM800A GSM Module**

The SIM800A GSM Module is a Quad Band GSM/GPRS device that supports 850/900/1800/1900 MHz of frequency. It can be used to transmit Voice Mail, SMS and other data info. It is very easy to embed this device as it acquires only a size of 100 x 53 x 15 (mm) and also it has a baud rate of 9600. [5]



Fig.7: SIM 800A GSM Module

**Use in our Project:**

Since the GPS device stores the location on Firebase Server therefore it will have a need of an Internet Connection. The SIM800A GSM Module helps us with that. It provides fast internet 2G/3G connectivity that can be used to transmit data at a high speed.

**III. WORKING**

Rakshak is an IoT-based solution that will harness the power of Sensors. The main objective of this project is to detect vehicle accidents and send an alert notification to concerned authorities to receive an effective immediate emergency response. There are 2 phases in this project, the first phase stores the data onto the server from the hardware device. And the second phase renders the location of the device in a Map View.

**3.1 Phase-1**

The main system of Hardware Device is chosen as Raspberry Pi over Arduino because of its fast processing speed and power. The Raspberry Pi has a connected Neo6M GPS Module which fetches the current location of the device. This module will keep on fetching the result until and unless it gets a specific type of signal from the Hit/Shock Sensor.

The Shock sensor records the intensity of hit/shock and checks whether the intensity is above the threshold value or not. In case it is above the set threshold mark, the hit/shock sensor sends an alert signal to Raspberry Pi. The Raspberry Pi will then trigger the main program. This main program takes the current location from the GPS Module and stores it on the Google Firebase Server.

The main program is also equipped with the feature of calling. This feature will alert all the nearby Police Stations and Hospitals with an automated Voice and Text Message on to their devices to receive an effective immediate emergency response.

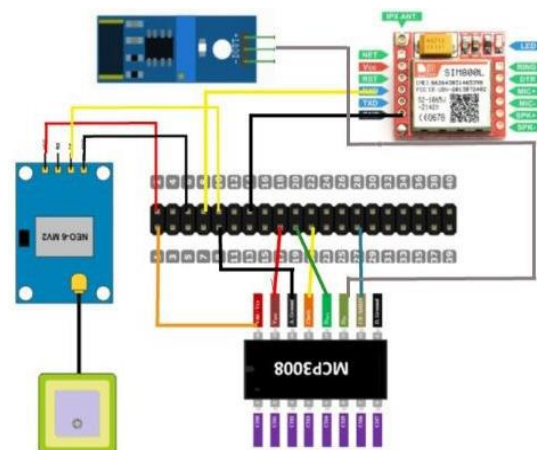

Fig.8: Hardware circuit of Rakshak

### 3.2 Phase-2

In phase 2 of this Project, a Mobile Application has been set up that helps to see the location of the device in a Fully Integrated Map View so that it becomes easy to track the accident location. The Mobile App fetches the location from the Google Firebase Server and renders it on the map with the help of OpenStreetMaps API. The App is built in Python-Kivy which provides several in-built plugins including the OpenStreetMaps API. The GPS Module in the Hardware device generates coordinates based on the location of the device and those coordinates are rendered on the map with a marker pointing to the actual location of the accident.

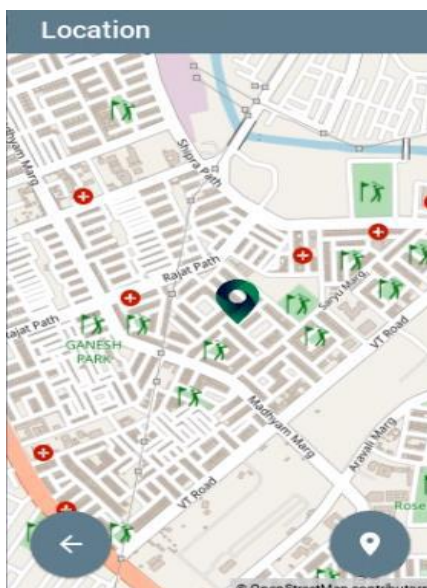

Fig.9: Mobile App – Location UI

### IV. CONCLUSION

This project has a huge scope in the field of the Automobile Industry and integrated GPS System Development Industry. The major advantage of this project is that it would help in decreasing the death toll due to road accidents by a huge margin.

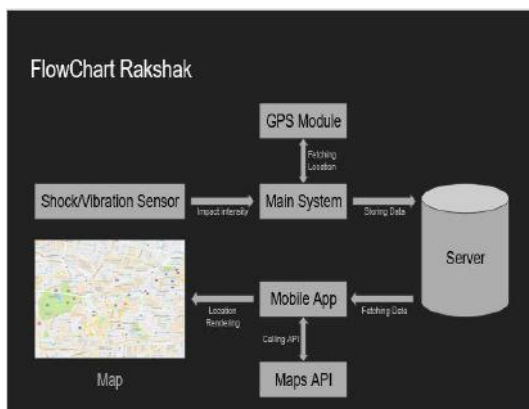

Fig.10 Rakshak Block Diagram

### REFERENCES

- [1] "Raspberry Pi - Wikipedia", *En.wikipedia.org*, 2021. [Online]. Available: [https://en.wikipedia.org/wiki/Raspberry\\_Pi](https://en.wikipedia.org/wiki/Raspberry_Pi). [Accessed: 18-Jun- 2021]. J. Clerk Maxwell, A Treatise on Electricity and Magnetism, 3rd ed., vol. 2. Oxford: Clarendon, 1892, pp.68–73.
- [2] "Raspberry Pi Analog to Digital Converters", *Adafruit Learning System*, 2021. [Online]. Available: <https://learn.adafruit.com/raspberry-pi-analog-to-digital-converters>. [Accessed: 18- Jun- 2021]. K. Elissa, "Title of paper if known," unpublished.
- [3] *Lastminuteengineers.com*, 2021. [Online]. Available: <https://lastminuteengineers.com/neo6m-gps-arduino-tutorial/>. [Accessed: 18- Jun- 2021].
- [4] "NEO-6 series", *u-blox*, 2021. [Online]. Available: <https://www.u-blox.com/en/product/neo-6-series>. [Accessed: 18- Jun- 2021].
- [5] "Buy SIM800A GSM Module with RS232 Interface Online at Lowest Price", *Robu.in | Indian Online Store | RC Hobby / Robotics*, 2021. [Online]. Available: <https://robu.in/product/sim800a-quad-band-gsmgprs-module-rs232-interface/>. [Accessed: 18- Jun- 2021].