

Design and Implementation of an Automatic Three-Phase Shifter for Phase Failure Protection

Jinendra Rahul^{*1}, Saurabh Kumar^{*2}, Naman Tiwari^{*3}, Mohit Kumar^{*4}, Yashasvansal^{*5}, Jitendra Singh^{*6}

^{*}Department of Electrical Engineering, Swami Keshvanand Institute of Technology, Management & Gramothan, Jagatpura, Jaipur 302017, Rajasthan, India.

¹Email: jinendra.r@gmail.com

²Email: b220842@skit.ac.in

³Email: b221456@skit.ac.in

⁴Email: b221157@skit.ac.in

⁵Email: b221465@skit.ac.in

⁶Email: jitendrasingh2389@gmail.com

Received: 15 Mar 2026; Accepted: 13 Apr 2026; Date of Publication: 21 Apr 2026

©2026 The Author(s). Published by Infogain Publication. This is an open-access article under the CC BY license (<https://creativecommons.org/licenses/by/4.0/>).

Abstract— Modern electrical systems need a reliable power supply, but phase failures in three-phase distribution networks often cause outages and damage to equipment. This paper proposes an automatic three-phase shifting system that keeps the supply going by dynamically choosing a phase that is available and healthy. The system uses voltage-sensing and signal-conditioning circuits to continuously monitor the conditions of each phase. It then uses a control unit to choose the best phase based on pre-set logic and safety thresholds. Switching is done with either relay-based or solid-state systems, which let the load move smoothly between phases when one or more of them fails. The proposed design improves operational reliability by reducing downtime, the need for manual intervention, and the risk of voltage imbalance and single phasing for connected loads. Recent implementations show that microcontroller-based control works well and that advanced switching technologies could make response times faster. The system is good for homes, businesses, and light industrial uses where a steady single-phase supply is important. Future improvements could include integrating with smart monitoring systems and high-speed semiconductor switching devices to improve performance.

Keywords— Load distribution, phase shifter, switching, conditioning, phase failure .

I. INTRODUCTION

Three-phase power systems are better than single-phase systems for generating, transmitting, and distributing electricity because they are more efficient, work more evenly, and deliver power all the time. These systems are a key part of modern infrastructure because they are needed to run industrial equipment, motors, and large electrical loads. However, keeping a balanced and steady three-phase supply in real life is still hard [1], [3].

A typical problem in these kinds of systems is the loss of one or more phases, which is often called single-

phasing or phase failure. This situation can happen because of problems like broken conductors, blown fuses, loose wiring, or problems with the distribution network. If one phase goes out, loads connected to that phase lose power. Three-phase machines may overheat, work less efficiently, or even get permanently damaged if they run unbalanced. Standard protective devices are made to cut off the system when these kinds of faults happen. This stops damage but doesn't guarantee that the supply will continue [2].

In the Indian context, these challenges are more pronounced due to factors such as rapid urbanization, uneven load distribution, aging infrastructure, and

frequent faults in rural and semi-urban power networks. It is not uncommon in many regions of India for only one or two phases to be available at a given time, especially in residential and agricultural supply lines. As a result, users often face unnecessary power outages despite the partial availability of the supply. Manual phase selection is sometimes used as a workaround, but it is unsafe, inefficient, and prone to human error [3].

To deal with these problems, systems that can automatically switch phases have become very important because they are practical and work well. These systems always check the condition of all three phases. Automatically switch the load to a healthy phase without needing someone to do it manually. This way we can keep the power on for things that make the system more reliable and reduce the chance of damaging equipment. With the help of computers and advanced sensors, modern systems that can automatically switch phases can make decisions quickly and switch faster and safer [2], [3].

This paper is about designing and building a system that can automatically switch between three phases to keep the power on if one phase fails. The system we are proposing is especially good for places like India, where the power supply's not always balanced and often gets interrupted. We are focusing on how the system's designed, how it works and how to actually build it so we can find a solution that is affordable and works well to make the power supply more reliable. The automatic three-phase shifter is what we are trying to develop to ensure power supply under phase failure conditions.

II. LITERATURE REVIEW

The development of automatic phase shifters is really important because we need a power supply in three-phase distribution systems. Many researchers have tried ways to fix phase failure problems and make the systems more reliable. They have used microcontrollers, analog circuits and solid-state devices to do this.

One way to automatically select phases is to use a microcontroller. V. S. Gadakh et al. [4] Showed how this can be done. They sense the phase voltages. Send the information to a microcontroller, which then makes decisions. The system uses relays to switch loads between phases and also senses the current to monitor and balance the loads. This approach is more efficient.

Reduces downtime, which makes it good for homes and industries.

Bawane et al. [5] Also proposed a way to automatically select phases. Their system can switch to another phase if one fails, without needing a power source. They use relays to sense and switch phases, which helps to detect phase failures. The system also senses the current to prevent overloading, which makes it safer and better. Automatic phase shifters, like these are very useful because they make sure we have power all the time.

Abutu [6] introduced an automatic phase changer with optimal phase selection capability. The design utilizes step-down transformers, rectifiers, and a microcontroller to evaluate phase voltages and select the phase with the highest stability. A key contribution of this work is the implementation of a priority-based logic system, where phases are selected based on predefined hierarchy. The inclusion of an LCD display for real-time status monitoring improves user interaction and system transparency.

An alternative approach using logic gates and relay control was presented by Usman [2], where phase availability is detected using simple electronic circuits without complex programming. The system automatically connects the load to an active phase and suggests the use of power semiconductor devices such as thyristors or IGBTs for faster switching in future designs. This work emphasizes simplicity and cost-effectiveness.

In addition to these designs, analog comparator-based systems using operational amplifiers (such as LM324) have also been explored. These systems detect voltage levels and select the phase with the highest voltage without requiring a microcontroller. While such designs are economical and easy to implement, they lack flexibility and advanced control features compared to digital systems.

Recent research underscores the inadequacies of traditional protection systems, which isolate loads during faults rather than ensuring supply continuity. Adamu et al. [3] says that single-phasing can seriously hurt motors by making them too hot and causing the current to be uneven. This shows how important automatic phase selection systems are for protecting equipment and making sure it keeps working.

Overall, the literature shows that automatic phase shifters that use microcontrollers are more flexible, more accurate, and more useful than analog systems. Relay-based switching, on the other hand, causes

delays, so researchers are looking into solid-state switching methods that work faster and more reliably. In the future, smart monitoring, IoT connectivity, and advanced control algorithms are expected to work together to make systems even more efficient and flexible.

III. PROPOSED METHODOLOGY

The methodology of the proposed automatic three-phase shifter focuses on the operational logic used to ensure uninterrupted power supply during phase failure conditions. The system continuously monitors the voltage status of all three input phases and dynamically selects a healthy phase based on predefined decision rules. This process is executed in a cyclic manner to provide real-time response to changing supply conditions, as illustrated in Fig. 1.

Initially, the voltages of the three phases are sensed and converted into low-level signals suitable for processing. These signals are evaluated against predefined threshold limits to determine whether each phase is available or faulty. Based on this evaluation, the control logic assigns a status to each phase [4].

A priority-based selection algorithm is then applied, typically following a sequence such as $R > Y > B$. If multiple phases are available, the system selects the highest-priority phase. In case the currently active phase fails, the system automatically switches to the next available phase. If no phase is available, the system disconnects the load to prevent damage [4], [5].

To ensure stability, the system incorporates a short delay and verification step before switching, preventing rapid or false transitions due to temporary fluctuations. This continuous loop of sensing, decision-making, and switching ensures reliable and autonomous operation without human intervention. [6]

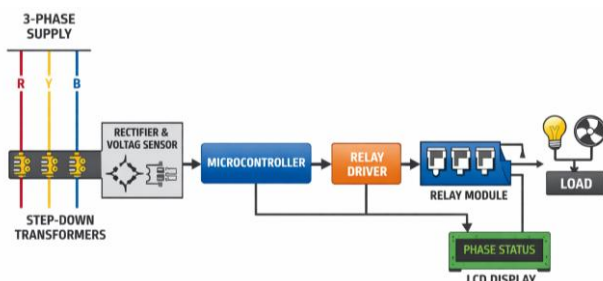

Fig. 1: Conceptual block diagram of an automatic phase selector for three-phase power systems.

IV. SYSTEM DESIGN

The system design of the automatic three-phase shifter focuses on the structural arrangement of hardware components required to achieve reliable phase selection and load transfer. The architecture is divided into multiple functional sections, each responsible for a specific task such as sensing, control, and switching. These sections are integrated to ensure safe interaction between high-voltage supply lines and low-voltage control circuitry [4].

At the front end, the three-phase supply is interfaced through protective elements to prevent damage due to abnormal conditions. Each phase is then routed to an isolation stage where its voltage is reduced to a manageable level. This ensures that subsequent electronic circuits operate within safe limits while maintaining accurate representation of the input conditions [5].

The conditioned signals are directed to the control hardware, which forms the decision-making core of the system. A microcontroller is employed to interpret the incoming signals and determine the status of each phase. Based on internal logic, it produces control outputs corresponding to the selected phase. The controller is supported by essential peripheral components such as regulated power supply units and timing circuits to maintain stable operation.

To enable actuation, the control signals are passed through an interfacing stage consisting of switching drivers. These drivers amplify the low-power signals generated by the controller so that they can operate electromechanical switching devices. Proper protection elements are included to suppress unwanted electrical disturbances during switching events [5].

The final stage of the design is the switching network, which connects the load to one of the available phases. The configuration is arranged such that only a single phase is connected at any instant, thereby eliminating the possibility of short circuits between phases. The switching elements are selected based on their current handling capacity and operational reliability under repeated switching conditions [4], [6].

Additional design provisions may include sensing mechanisms for monitoring load conditions and enhancing protection capability. The overall system is powered through a dedicated low-voltage supply unit that ensures uninterrupted operation of the control and driver circuits [7].

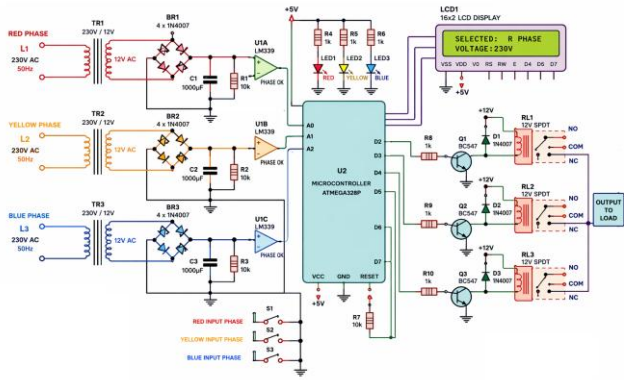

Fig. 2: Complete hardware configuration of the proposed system.

The complete hardware configuration of the proposed system is illustrated in Fig. 2, which presents the detailed circuit layout including sensing circuits, control interface, driver stage, and relay-based switching arrangement.

V. RESULTS AND DISCUSSION

The proposed automatic three-phase shifter was evaluated under different operating conditions to examine its ability to maintain continuous power supply during phase failure scenarios. The system was tested by varying the availability of input phases (R, Y, B) and observing the response of the sensing, control, and switching units. The results confirm that the system reliably detects phase conditions and automatically transfers the load without requiring manual intervention.

The circuit operates by continuously monitoring the voltage levels of all three phases. Each phase is stepped down, rectified, filtered, and converted into a DC signal proportional to its voltage. These conditioned signals are processed by the control unit, which compares them with predefined threshold values to determine whether a phase is healthy or faulty. Based on this evaluation, the controller executes a priority-based decision logic to select the most suitable phase.

During normal operation, when all three phases are available, the system consistently selects the highest-priority phase (R phase), confirming correct implementation of the control logic. If the R phase becomes unavailable, the system automatically switches to the next available phase (Y phase), and subsequently to the B phase if required. This transition is achieved through relay-based switching controlled by transistor driver circuits. At any instant, only one

relay remains active, ensuring that the load is connected to a single phase and preventing phase-to-phase faults.

In conditions where only one phase is available, the system continues to supply power by connecting the load to that phase. This feature is particularly useful in practical scenarios where partial phase availability is common. When all phases are unavailable, the system disconnects the load, thereby protecting connected equipment from unsafe operating conditions.

The operational behavior of the system is summarized in Table 1, which represents the priority-based phase selection logic:

Table 1: Phase Selection Logic

R	Y	B	Selected Phase	Operation
0	0	0	None	Load disconnected
0	0	1	B	Load connected to B
0	1	0	Y	Load connected to Y
0	1	1	Y	Y selected (higher priority than B)
1	0	0	R	Load connected to R
1	0	1	R	R selected (higher priority than B)
1	1	0	R	R selected (higher priority than Y)
1	1	1	R	All phases available, R selected

This logic demonstrates a simple yet effective priority-based control strategy that ensures reliable phase selection under all possible conditions.

The experimental observations also indicate that the relay switching mechanism operates reliably under repeated transitions. However, a minor switching delay is present due to the mechanical nature of relays. While this delay does not significantly affect general applications, it may not be suitable for highly sensitive equipment requiring instantaneous switching. The voltage sensing circuit provided stable and accurate detection, even under moderate fluctuations, due to proper signal conditioning and isolation.

From a practical perspective, the system offers a cost-effective and efficient solution for improving power reliability. It reduces downtime, eliminates manual switching risks, and enhances protection of electrical loads. This is especially relevant in regions with

frequent phase imbalance and supply interruptions, such as many parts of India.

Despite its advantages, the system has certain limitations. It is primarily designed for single-phase loads and may not be suitable for heavy three-phase machinery. Additionally, relay wear over long-term operation may require maintenance. Future improvements may include the use of solid-state switching devices for faster response, intelligent load balancing techniques, and integration with smart monitoring systems for enhanced functionality.

VI. CONCLUSION

This paper presented the design and evaluation of an automatic three-phase shifter developed to maintain continuous power supply during phase failure conditions. The proposed system successfully monitors the status of each phase and automatically connects the load to the most suitable available phase using a priority-based control approach. The implementation demonstrates that reliable phase detection and switching can be achieved using simple sensing circuits, a microcontroller-based decision unit, and relay-driven switching mechanisms.

The results confirm that the system effectively handles various operating scenarios, including single-phase failure, dual-phase availability, and complete loss of supply. By eliminating the need for manual phase selection, the system improves safety, reduces downtime, and enhances the protection of connected loads against voltage imbalance and single-phasing effects. Its cost-effective design and use of readily available components make it practical for deployment in residential, commercial, and small industrial environments.

Despite its effectiveness, the system has certain limitations, particularly the switching delay associated with electromechanical relays and its suitability primarily for single-phase loads. These constraints can be addressed in future work by incorporating solid-state switching devices, faster control techniques, and intelligent load management strategies. Additionally, integration with digital monitoring systems and smart grid technologies can further enhance performance and adaptability.

Overall, the proposed automatic phase shifter provides a simple, reliable, and efficient solution to improve power availability and operational continuity,

especially in regions where phase imbalance and supply interruptions are frequent.

REFERENCES

- [1] E. Khojiakbar, I.Kh. Kholiddinov, A. Eraliev, S. Tukhtasinov and S. Komolddinov, "Development of simulation model of smart phase selector device", Rudenko International Conference on Methodological Problems in Reliability Study of Large Energy System (RSES 2023), Volume 461, Dec. 2023.
- [2] Usman, "Design and construction of an automatic phase selector for 3-phase power supply", International Journal of Innovative Scientific & Engineering Technologies Research (IJSETR), vol. 12, issue no. 3, pp. 64-70, 2024.
- [3] A. D. Adamu et al., "Construction of automatic phase selector for steady power supply", International Journal of Development Mathematics (IJDM), Vol. 2, issue. 3 pp. 176- 187, 2025.
- [4] V. S. Gadakh, S. P. Patil, and P. R. Patil, "Auto Phase Selector for Available Phase in 3-Phase Supply", International Research Journal of Engineering and Technology (IRJET), vol. 8, issue no. 2, pp. 134-138, Feb. 2021.
- [5] S. Bawane, A. Kapse, and R. Wagh, "Automatic Phase Selector Implementation Using Amongst Available Phase Supply", International Journal of Progressive Research in Engineering Management and Science (IJPREMS), vol. 3, issue no. 5, May 2023.
- [6] S. Abutu, "Automatic Phase Changer with Optimal Selection", International Journal of Latest Technology in Engineering, Management & Applied Science (IJLTEMAS), vol. 9, issue no. 5, pp. 93-96, 2020.
- [7] M. H. Rashid, "Power Electronics: Circuits, Devices, and Applications", 4th ed., Pearson, 2014.